

Power Optimizer

USA Domestic Content Eligible*

For North America

U650 / U650B



POWER OPTIMIZER



SolarEdge's USA-manufactured offering for PV power optimization at the module level

- Eligible for domestic content: SolarEdge USA-manufactured Power Optimizers*, when paired with certain SolarEdge inverters, are intended to be eligible for the enhanced federal income tax credit for domestic content
- Specifically designed to work with SolarEdge inverters
- Supports high open circuit voltage (Voc) modules with U650B
- U650B provides improved design flexibility of multifaceted, complex roofs, with extended output voltage that reduces yield factor losses
- Superior efficiency (99.5%)
- Mitigates diverse types of module mismatch loss, from manufacturing tolerance to partial shading
- Flexible system design for maximum space utilization
- Faster installations with simplified wire management and easy assembly using a single bolt
- Compatible with a wide range of modules, including high-powered and bifacial PV modules
- Advanced safety:
 - Patented Sense Connect technology, designed to automatically detect and prevent potential electric arcs at the connector level before an arc is created
 - Patented SafeDC™ – module-level voltage shutdown, for installer and firefighter safety
 - Meets NEC requirements for arc fault protection (AFCI) and Photovoltaic Rapid Shutdown System (PVRSS)

* Manufactured by SolarEdge with the intent to be eligible for inclusion under the elective safe harbor in calculating the Domestic Content Percentage under the "Rooftop (MLPE)" category (under IRS Notice 2024-41). The PCBA, Electrical Parts, and Enclosure are domestically manufactured to meet the requirements of eligibility to be considered for the ITC domestic content bonus adder. SolarEdge does not provide tax and/or legal advice. You should consult with your own legal and/or tax advisor(s) regarding the eligibility of your project for the ITC or PTC, including the 10% domestic content bonus, to determine how the applicable rules apply to your particular project. The forward-looking statements in this datasheet are accurate as of the date herein and are subject to change. For more information, please contact your local SolarEdge sales representative.

/ Power Optimizer

USA Domestic Content Eligible, for North America

U650 / U650B

	U650	U650B	Units
INPUT			
Rated Input DC Power ⁽¹⁾	650		W
Absolute Maximum Input Voltage (Voc)	60	100	Vdc
MPPT Operating Range	8 – 60	12.5 – 100	Vdc
Maximum Continuous Input Current	15		Adc
Maximum Input Current (Maximum Isc of Connected PV Module)	16.5 for Solaredge Home Hub Single Phase Inverters 15 for all other SolarEdge inverters		Adc
Maximum Input Short Circuit Current ⁽²⁾	25		Adc
Maximum Efficiency	99.5		%
Weighted Efficiency	98.6		%
Overvoltage Category	II		
OUTPUT DURING OPERATION (POWER OPTIMIZER CONNECTED TO OPERATING SOLAREEDGE INVERTER)			
Maximum Output Current	15		Adc
Maximum Output Voltage	60	80	Vdc
OUTPUT DURING STANDBY (POWER OPTIMIZER DISCONNECTED FROM SOLAREEDGE INVERTER OR INVERTER OFF)			
Safety Output Voltage per Power Optimizer	1 ± 0.1		Vdc
STANDARD COMPLIANCE			
Photovoltaic Rapid Shutdown System	CSA C22.2#330, NEC 2014 – 2023		
EMC	FCC Part 15 Class B, IEC 61000-6-2, IEC 61000-6-3		
Safety	CSA C22.2#107.1, IEC 62109-1 (Class II safety), UL 1741		
Material	UL 94 V-0, UV Resistant		
RoHS	Yes		
Fire Safety	VDE-AR-E 2100-712:2013-05		
INSTALLATION SPECIFICATIONS			
Maximum Allowed System Voltage	1000		Vdc
Dimensions (W x L x H)	129 x 155 x 30 / 5.07 x 6.10 x 1.18	129 x 165 x 45 / 5.07 x 6.49 x 1.77	mm / in
Weight	720 / 1.6	790 / 1.74	gr / lb
Input Connector	MC4		
Input Wire Length	0.1 / 0.32		m / ft
Output Connector	MC4		
Output Wire Length	(+) 2.3, (-) 0.10 / (+) 7.54, (-) 0.32		m / ft
Operating Temperature Range ⁽³⁾	-40 to +85		°C
Protection Rating	IP68 / NEMA6P		
Relative Humidity	0 – 100		%

(1) The Rated Power of the module at STC will not exceed the power optimizer's Rated Input DC Power. Modules with up to +5% power tolerance are allowed.

(2) The Maximum Input Short Circuit Current is adjusted for worst case conditions of ambient temperature, irradiance, bifacial gain, and so on, in accordance with NEC and CSA.

(3) Power derating is applied for ambient temperatures above +85°C / +185°F for U650 and for ambient temperatures above +75°C / 167°F for U650B. Refer to the [Power Optimizers Temperature Derating](#) technical note for details.

PV System Design Using a SolarEdge Inverter	SolarEdge Home Hub Single Phase	Three Phase for 208V Grid	Three Phase for 277/480V Grid	Units
Minimum String Length (Power Optimizers)	U650	8	10 ⁽⁴⁾	
	U650B	6	8	
Maximum String Length (Power Optimizers)	25		50 ⁽⁵⁾	
Maximum Usable Power Delivered per String	5700	6000	12,750	W
Maximum Allowed Connected Power per String ⁽⁶⁾⁽⁷⁾	Inverters with Rated AC Power ≤ 5760W	Per the inverter's maximum input DC power ⁽⁸⁾	15,000	W
	Inverters with Rated AC Power ≥ 7600W	One string: 5700 Two strings or more: 6800		
Parallel Strings of Different Lengths or Orientations	Yes			

(4) For the SE17.3KUS Three Phase Inverter and the SE50KUS Three Phase Inverter with Synergy Technology, the minimum string length is 11 Power Optimizers.

(5) A string with more than 30 optimizers does not meet NEC rapid shutdown requirements; safety voltage will be above the 30V requirement.

(6) For the 208V grid, the maximum is permitted only when the difference in connected power between strings is 1000W or less.

(7) For the 240V or 277/480V grids, the maximum is permitted only when the difference in connected power between strings 2000W or less.

(8) Refer to the [Single String Design Guidelines](#) application note for more details.

/ Power Optimizer

USA Domestic Content Eligible, for North America

U650 / U650B

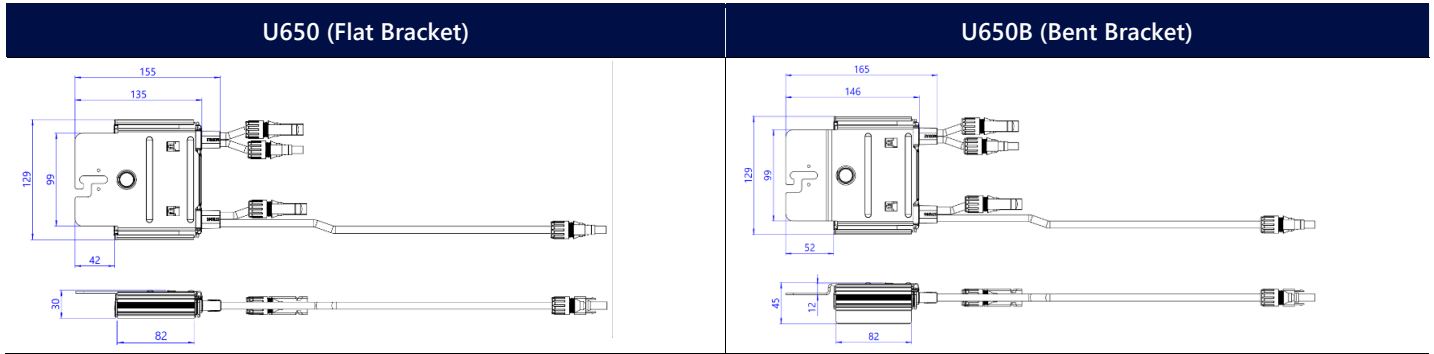

SolarEdge is a global leader in smart energy technology. By leveraging world-class engineering capabilities and with a relentless focus on innovation, SolarEdge creates smart energy solutions that power our lives and drive future progress.

SolarEdge developed an intelligent inverter solution that changed the way power is harvested and managed in photovoltaic (PV) systems. The SolarEdge DC optimized inverter maximizes power generation while lowering the cost of energy produced by the PV system.

Continuing to advance smart energy, SolarEdge addresses a broad range of energy market segments through its PV, storage, EV charging, UPS, and grid services solutions.

-  SolarEdge
-  @SolarEdgePV
-  @SolarEdgePV
-  SolarEdgePV
-  SolarEdge
-  www.solaredge.com/corporate/contact

solaredge.com

© SolarEdge Technologies, Ltd. All rights reserved. SOLAREEDGE, the SolarEdge logo, OPTIMIZED BY SOLAREEDGE are trademarks or registered trademarks of SolarEdge Technologies, Inc. All other trademarks mentioned herein are trademarks of their respective owners. Date: January 6, 2026 DS-000247-NAM Subject to change without notice.

Cautionary Note Regarding Market Data and Industry Forecasts: This brochure may contain market data and industry forecasts from certain third-party sources. This information is based on industry surveys and the preparer's expertise in the industry and there can be no assurance that any such market data is accurate or that any such industry forecasts will be achieved. Although we have not independently verified the accuracy of such market data and industry forecasts, we believe that the market data is reliable and that the industry forecasts are reasonable.

solaredge