

PART # TABLE	
P/N	DESCRIPTION
SHCPKTM1	STRONGHOLD ATT KIT COMP MILL
SHCPKTD1	STRONGHOLD ATT KIT COMP DRK
SHCPKTM1-NS	STRONGHOLD ATT COMP MILL (NS)
SHCPKTD1-NS	STRONGHOLD ATT COMP DRK (NS)

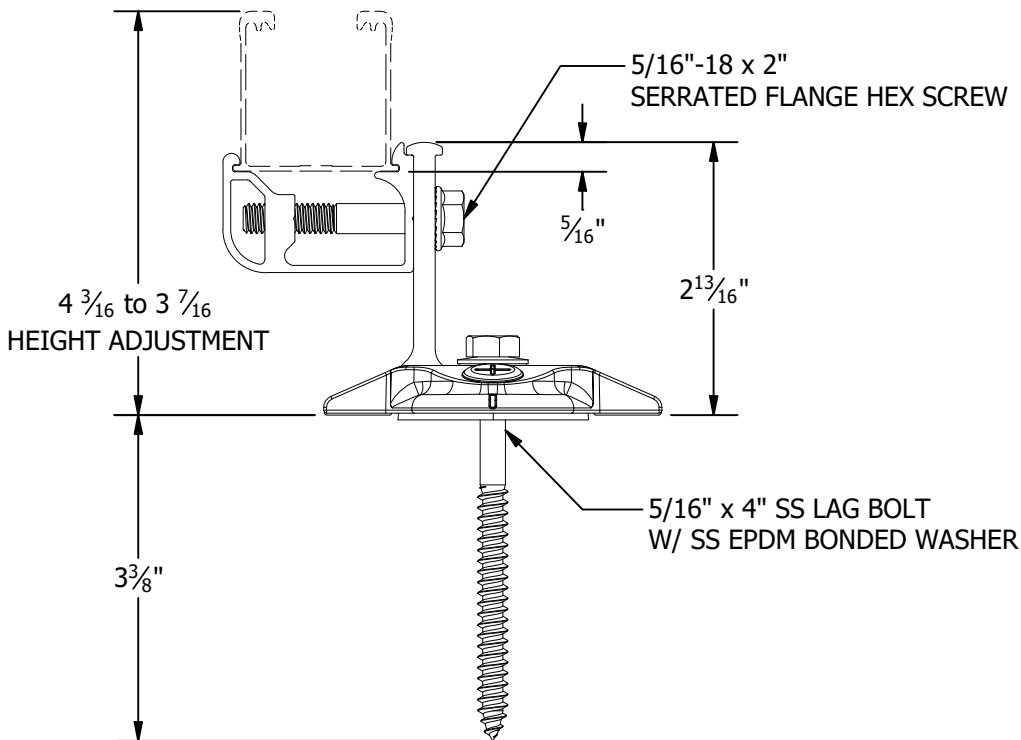
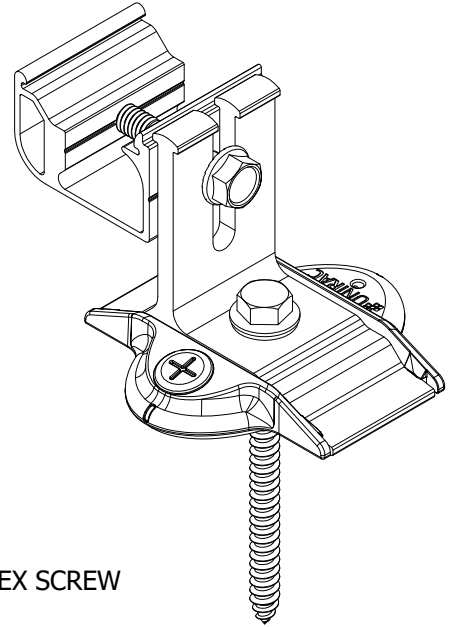
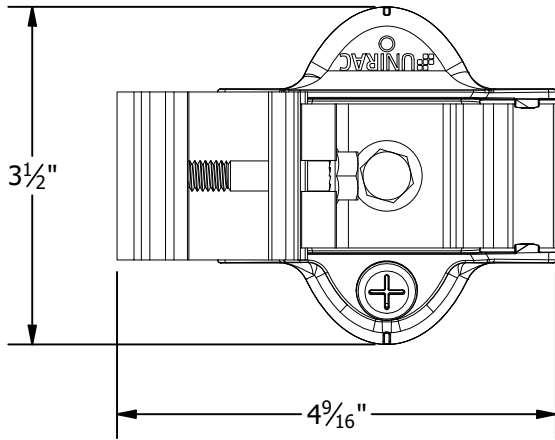

1411 BROADWAY BLVD. NE
ALBUQUERQUE, NM 87102 USA
PHONE: 505.242.6411
WWW.UNIRAC.COM

PRODUCT LINE:	NXT UMount
DRAWING TYPE:	PARTS ASSEMBLY
DESCRIPTION:	STRONGHOLD ATTACHMENT
REVISION DATE:	11/17/2022

DRAWING NOT TO SCALE
ALL DIMENSIONS ARE
NOMINAL

PRODUCT PROTECTED BY
ONE OR MORE US PATENTS
LEGAL NOTICE

NU-A04

SHEET