

DESCRIPTION:
SNAPNRACK, TDS, ULTRA RAIL COMP KIT (USA)

DOC NUMBER:
 SNR-DC-01442

SnapNrack®

PART NUMBER(S):
 232-01375, 242-01220-USA, 242-92266

DRAWN BY:
 M.WATKINS

REV: **B** DATE:
 8/11/2025

SNR SOLAR LLC
 775 FIERO LANE, SUITE 200
 SAN LUIS OBISPO, CA 93401 USA
 EMAIL: CONTACT@SNAPNRACK.COM
THE INFORMATION IN THIS DRAWING IS CONFIDENTIAL AND PROPRIETARY. ANY REPRODUCTION, DISCLOSURE, OR USE THEREOF IS PROHIBITED WITHOUT THE WRITTEN CONSENT OF SNR SOLAR LLC.

UNITS: IN, LB, DEG [MM, KG, DEG] SHEET: 1:1

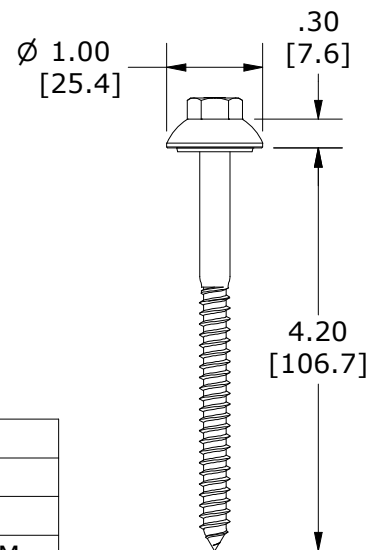
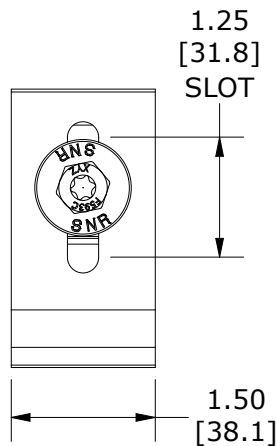
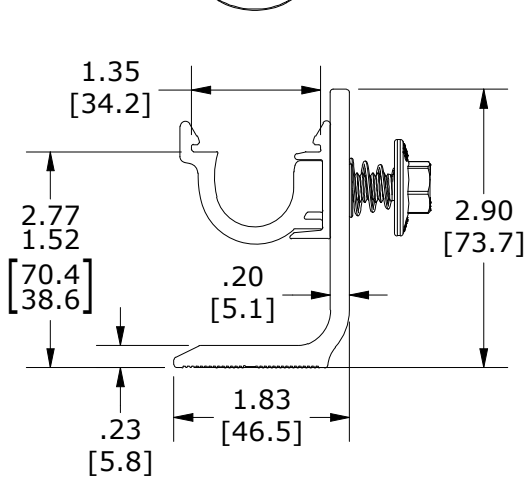
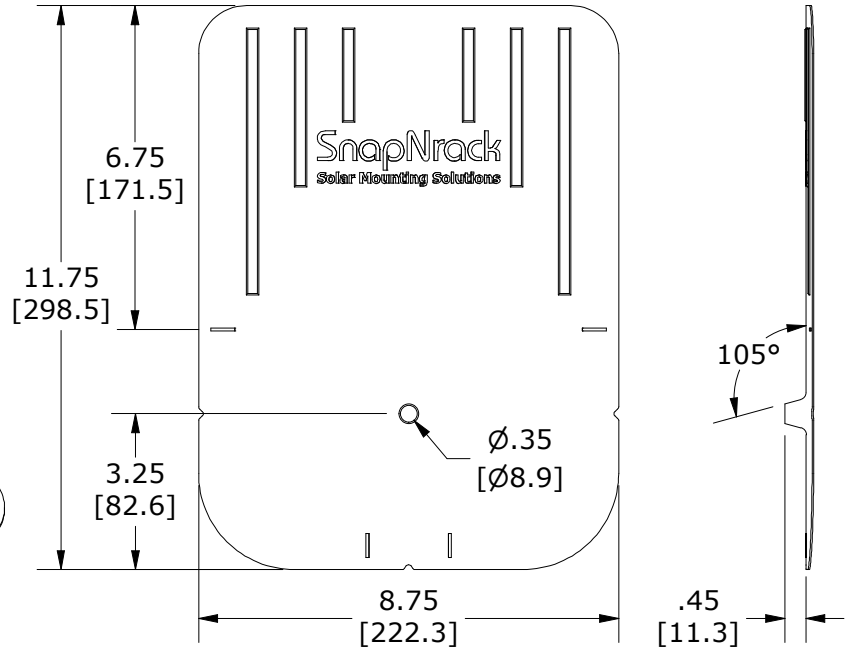
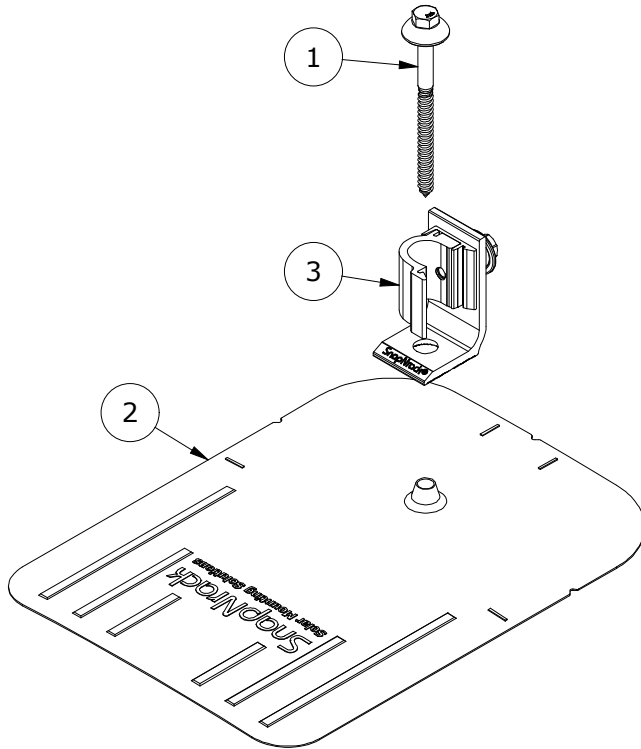

PARTS LIST

ITEM	QTY	PART NUMBER	DESCRIPTION
1	1	242-92266	SNAPNRACK, UMBRELLA LAG, TYPE 3, 4IN, SS
2	1	232-01375	SNAPNRACK, COMP FLASHING, 9IN X 12IN, BLACK ALUM
3	1	242-01220-USA	SNAPNRACK, ULTRA RAIL UMBRELLA L FOOT, BLACK (USA)

MATERIALS:	6000 SERIES ALUMINUM, STAINLESS STEEL, RUBBER
DESIGN LOAD (LBS):	802 UP, 1333 DOWN, 356 SIDE
ULTIMATE LOAD (LBS):	2005 UP, 4000 DOWN, 1070 SIDE
TORQUE SPECIFICATION:	12 FT-LBS
CERTIFICATION:	UL 2703, FILE E359313; WIND-DRIVEN RAIN TEST FROM UL SUBJECT 2582
WEIGHT (LBS):	0.71