

Standoffs Installation Manual

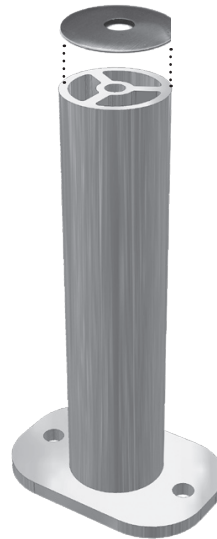

[1] Installer responsibility



The installer is solely responsible for:

- Complying with all applicable local or national building codes, including any that may supersede this manual;
- Ensuring that Unirac and other products are appropriate for the particular installation and the installation environment;
- Ensuring that the roof, its rafters, connections, and other structural support members can support the array under building live load conditions;
- Using only Unirac parts and installer-supplied parts as specified by Unirac (substitution of parts may void the warranty);
- Maintaining the waterproof integrity of the roof; and
- Ensuring safe installation of all electrical aspects of the PV array.



See www.unirac.com/distributors for your nearest Unirac distributor.

PUB 180119
JAN 2018

© 2018 by Unirac, Inc.
All rights reserved.

Standoffs: 3-, 4-, 6-, and 7-inch lengths available

	Shaft O.D.	Use	Components
<p>Flat top 2-piece aluminum</p> 	1 5/8"	Use with SunFrame, SolarMount Standard, SolarMount Light, or SolarMount HD rails. Secure to rafter with 2 lag screws (sold separately). Secure L-foot or installer-supplied strut directly to standoff with standoff hardware. Especially convenient when installing over a tile roof because flashing can be precisely fitted over secured base prior to installation of shaft.	<ul style="list-style-type: none"> • Shaft • Base assembly • Bolt, 3/8" x 3/4" Flange Head • EPDM Washer • 2 Lags (5/16") sold separately

* The installer is solely responsible for determining whether lags are adequate to handle live and dead loads under wind conditions at the installation site. Wind loads and lag pullout capacities are addressed in Code-Compliant installation manual for SolarMount (Installation Manual 227) and SunFrame (Installation Manual 809).

Flashings for all current standoffs (1 5/8" O.D. shaft)(see illustrations, p. 3)

	Part no.*	Dimensions
Collared, aluminum	004015C	9" x 12"
Collared, soft aluminum	004013C	18" x 18"

*Packs of 12 flashings.

Flashing refers to thin, continuous pieces of sheet metal or other impervious material installed to prevent the passage of water into a structure from an angle or joint.

Flashing generally operates on the principal that, for water to penetrate a joint, it must work itself upward against the force of gravity or in the case of wind-driven rain, it would have to follow a tortuous path during which the driving force will be dissipated.

Unirac offers flashings to be used specifically with Unirac standoffs. These flashings are collared, thereby eliminating the need for the use of sealant between standoff and flashing. The flashing slides over the standoff, under the shingle above, and over the shingle below.

The following installation instruction provides an explanation of planning and installation of two different applications.

Planning and installation

There are many possible configurations of standoffs and flashing. The two examples here illustrate major product varieties and installation settings.

Example 1

2-piece, aluminum, flat top standoff
Soft aluminum flashing
Tile roof
SunFrame (shown) or SolarMount rail

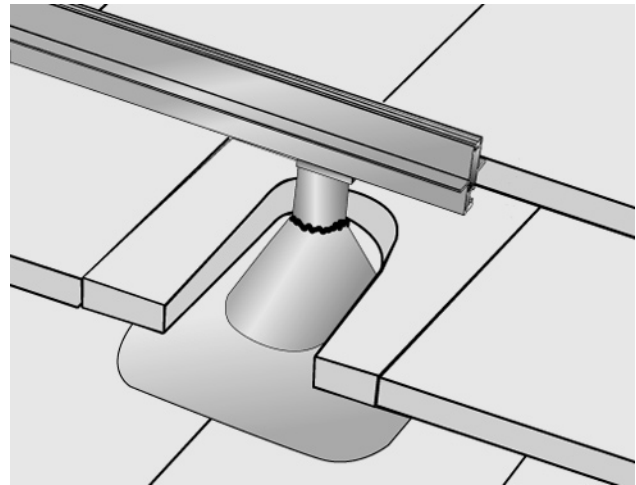
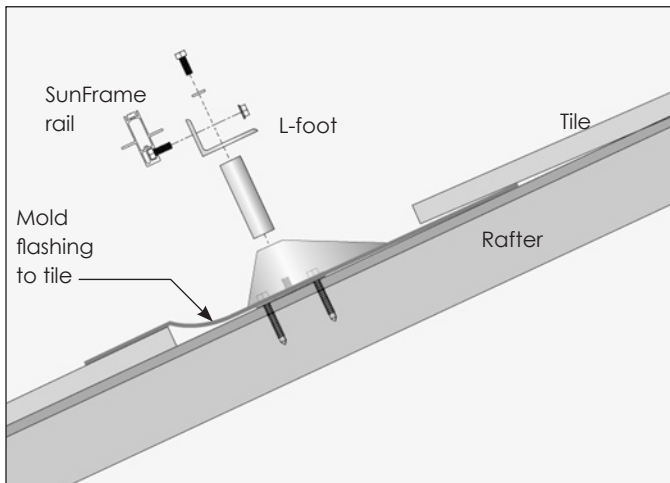

Remove a tile over a rafter. Install the base of a two-piece standoff, ensuring that both lag bolts are screwed into the rafter. Install soft aluminum flashing over the base, inserting it under the tile above and forming it to the shape of the tile. Insert standoff shaft through the opening in the flashing, screwing it down firmly in place onto the base. Seal with roofing cement or other appropriate compound.

Attach L-feet to standoffs. Slide L-foot mounting bolts along slot on SunFrame (or SolarMount) rail. Insert footing bolts through L-feet and fasten with flange nuts.

Example 2

2-piece, aluminum, flat top standoff
No-Calk™ flashing
Shingled roof
SunFrame (shown) or SolarMount rail

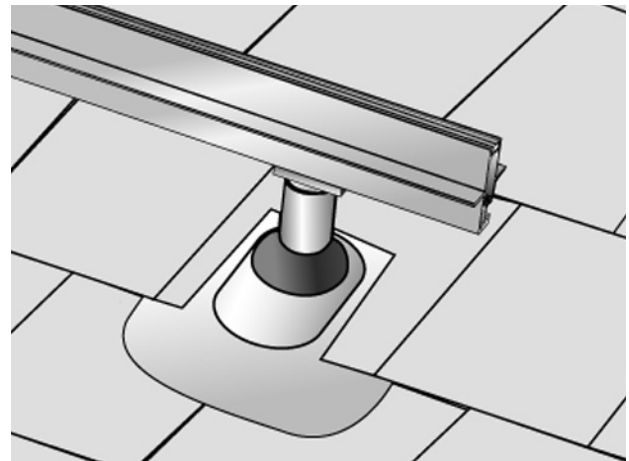
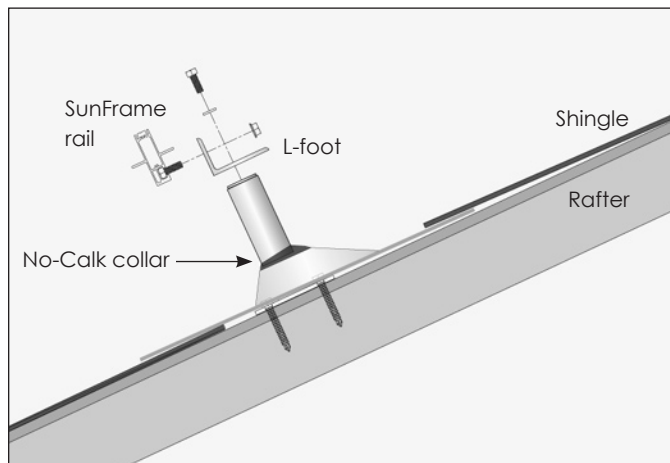

Cut an opening in the roofing material over a rafter to accommodate the flashing riser. Install the standoff, ensuring that both lag bolts are screwed into the rafter. Insert the flashing under the shingle above and over the shaft of the standoff. No-Calk collar does not require sealing of the flashing and standoff shaft.

Attach L-feet to standoffs. Slide L-foot mounting bolts along slot on SunFrame (or SolarMount) rail. Insert footing bolts through L-feet and fasten with flange nuts.

Warranty Information

See <http://www.unirac.com> for current warranty documents and information.